

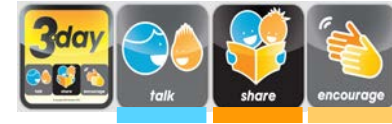

# The Winchester School

## Year 3 Family Learning Newsletter **February 2022**

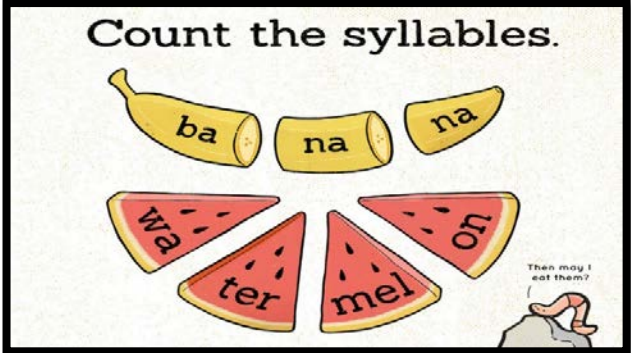

Area for learning	Focus	Activities	Useful Websites/Apps						
Literacy	<p><b>Spellings:</b></p> <ul style="list-style-type: none"> <li>To spell words of two or more syllables.</li> </ul> 	<p>Talk to your child about word syllables.</p> <p>Discuss words that have one or more than one syllable.</p> <p>For example: <b>Red</b> has only one syllable</p> <p>Pur-ple has two syllables.</p> <p>Encourage your child to break these words into syllables.</p> <table border="1" data-bbox="1055 863 1733 986"> <tbody> <tr> <td>hand</td> <td>Gi-gan-tic</td> </tr> <tr> <td>De-ve-lop</td> <td>E-le-phant</td> </tr> <tr> <td>peach</td> <td>Pa-per</td> </tr> </tbody> </table> <p>Another good method for teaching how to count syllables is to put your hand under your chin. Say the word and count the number of times your jaw drops.</p>	hand	Gi-gan-tic	De-ve-lop	E-le-phant	peach	Pa-per	<p><a href="#">Syllables</a></p> <p><a href="#">(23) Syllables!   Scratch Garden - YouTube</a></p>
hand	Gi-gan-tic								
De-ve-lop	E-le-phant								
peach	Pa-per								



# The Winchester School

## Year 3 Family Learning Newsletter **February 2022**

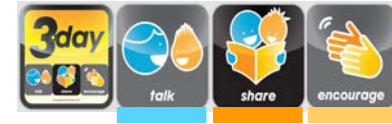

### **Punctuation:**

To use capital letters in sentences.

To use end stops such as full stops, question marks or exclamation marks to end sentences.

### **Grammar:**

#### **Connectives**

**What is a Connective?**

Connectives are words which join two pieces of text to each other. Connectives can be conjunctions, prepositions or adverbs and we use them constantly in written and spoken English.

**An example of a Connective?**

The connective word is highlighted in red.

- I chose a burger **because** I like fast food.
- I love roller coasters **and** adore log flumes.
- She went to the garden **before** coming inside.



**Talk** to your child about the use of punctuation marks in a book, newspaper or magazine article.

**Encourage** your child to identify the different punctuations added to paragraphs.

**Discuss** how some sentences use different punctuations and guide your child to highlight them in a text.

#### **Connectives:**

**Discuss** how sentences can be extended with connectives.

**Encourage** your child to choose different connectives to extend sentences.

**Talk** to your child about connectives that begin sentences.

[Punctuation super marks](#)

[Punctuation guessing game](#)



[Connectives for grammar](#)

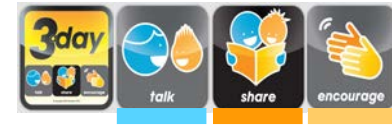

### Imperative Verbs

#### What is an imperative verb?

- It is a bossy verb! It makes a sentence bossy! Use Miss Bossy to help you remember!
- It gives you an order or command.
- They are direct and sharp.
- E.g. Line up for assembly.
- Turn left at the traffic lights.
- Mix the flour and eggs together.



### Text Level:

#### Non-Fiction Instruction Texts

- To read and explore instructional texts.
- To create a set of useable instructions.
- To convert visual information into written instructions.

Discuss that an imperative verb is one that tells **someone to do something**, so that the sentence it is in becomes an order or command.

Encourage your child to give commands which begin with imperative verbs.

**Example:** Wait quietly before class.

Be nice to your brother or sister.

Don't forget your bag!

Have a cooking session with your child allowing him/ her to read the instructions and you follow them or vice versa. Give clear and detailed instructions when you ask your child to perform a task.

**Encourage** your child to make a sandwich, by following a recipe.

**Talk** to your child on how to give directions in an engaging way.

### Imperative verbs:

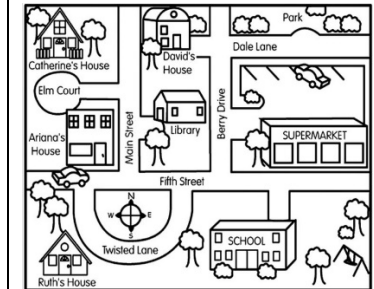

#### What are Imperative verbs?

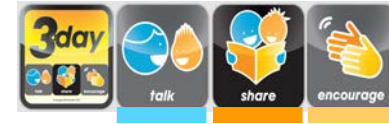

#### following directions

#### Instruction text features





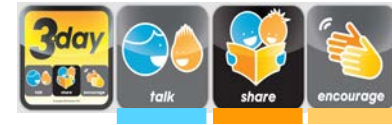

	<p style="text-align: center;"><b>Letter Writing</b></p>  <p><b><u>Non-Fiction- Writing an Informal letter</u></b></p> <p>To understand structure and layout including use of paragraphs, ways of starting and ending,</p> <p><b>Friendly letters have five parts:</b></p> <ul style="list-style-type: none"> <li>● The Heading</li> <li>● The Salutation (greeting)</li> <li>● The Body</li> <li>● The Closing</li> <li>● The Signature</li> </ul> 	<p><b>Encourage</b> your child to give you instructions on how to play his/her favourite game.</p> <p>Later, <b>share</b> the instructions you found easy to follow, and which ones were confusing.</p> <p><b>Encourage</b> your child to read variations of letters. (letters to friends and family who are far away from home; persuasive letters to their librarian requesting that specific texts to be added to the school library; letter to their favourite author, email, letter to the editor of a kid magazine)</p> <p>Plan a small party at home, where the child will be in charge of the invitations.</p> <p><b>Share</b> with your child the details of the party so that the same can be included in the invite.</p>	<p><a href="#">Friendly letter</a></p> 
<p><b>Geometry- 2D and 3D Shapes</b></p>	<p><b><u>Shapes</u></b></p> <p>To be able to identify 2D and 3D shape.</p>	<p><b>Talk</b> to your child about the different 2D and 3D shapes they see around them e.g. road sign boards, items found in the kitchen.</p> <p><b>Encourage</b> your child to open an empty cereal box, undo all flaps, check its net and sketch it on paper. Identify the shapes you have sketched.</p>	<p><a href="#">Find a Shape</a></p>

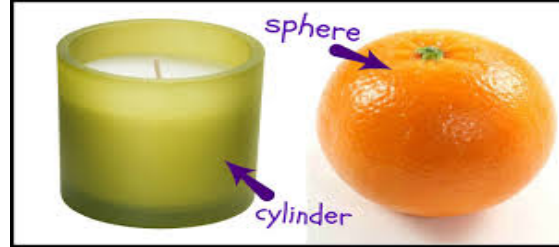

### Properties of Shapes



Ask your child with riddles based on shapes.



	This 3D shape is a _____ It has _____ Faces: _____ Vertices: _____
	This 3D shape is a _____ It has _____ Faces: _____ Vertices: _____
	This 3D shape is a _____ It has _____ Faces: _____ Vertices: _____
	This 3D shape is a _____ It has _____ Faces: _____ Vertices: _____
	This 3D shape is a _____ It has _____ Faces: _____ Vertices: _____

**Talk** about why we measure different objects in our daily life. Let your child measure and compare the length of different objects at home like clothes, shoes etc.



### Solid Shapes

Drag the shapes into the chart.

rectangular prisms	cubes
	



# The Winchester School

## Year 3 Family Learning Newsletter February 2022

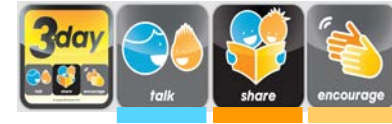

### Measurement - Length

#### Length













- To draw or measure lines in centimetres and millimetres.



length.

- To solve word problems involving

Use RUCSAC to solve word problems:









	<b>Read</b> 	<b>Read the question carefully</b>
	<b>Underline</b> 	<b>Underline the keywords and numbers</b>
	<b>Choose</b> 	<b>Choose the correct operation(s) and a mental or written method of calculation.</b>
	<b>Solve</b> 	<b>Solve it! Make sure you follow the steps.</b>
	<b>Answer</b> 	<b>Check that you've answered the question. What did you need to find out in the first place?</b>
	<b>Check</b> 	<b>Check your answer. Use another method or checking technique (was it close to your estimate?)</b>

Ask questions like who wears the biggest shoe in the family? How many cm long is it? How much longer is it than your shoe?

**Challenge** your child with measurement treasure hunt:

**Measure Treasure Hunt**

Use a ruler to measure these objects you can find around your home. Write how long they are. Circle the longest object and put a square around the shortest object.

 _____ inches	 _____ inches
 _____ inches	 _____ inches
 _____ inches	 _____ inches
 _____ inches	 _____ inches

#### Measure it

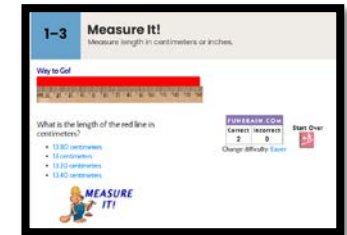



# The Winchester School

## Year 3 Family Learning Newsletter **February 2022**

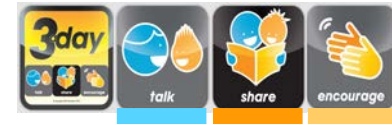

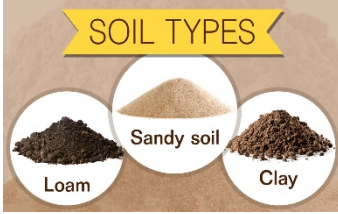
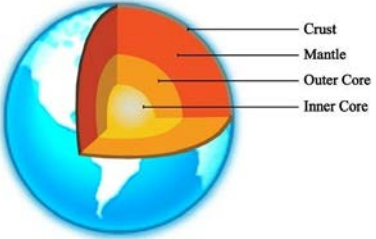

<p><b>Science</b></p>	<p><b>UNIT - Rocks and Soils</b></p> <p>To recognise and understand what is soil made of.</p> <p>To identify the layers of the earth.</p> <p>To explore and identify the three major types of rocks.</p> <p>To identify the uses of different types of rocks in our daily lives.</p> <p>To consider properties of rock and their uses as a building material.</p> <p>That rocks can be tested and compared on the basis of permeability and hardness</p> <p>Moral Education Link:</p> <p>Unit 3 – Lesson 5</p> <p>We are archaeologists.</p>	<p>Go on a tour of your local area – Park, garden or building compound.</p> <p><b>Observe</b> samples of stone and stone-like features in and around the house, e.g. walls, roofs, steps, garden tracks, gate-posts, paved areas, gravelled pathways etc.</p> <p><b>Share</b> with your child, videos on the local environment. Observe construction sites and garden centres in the local area. Collect samples of different types of rocks.</p> <p><b>Research</b> on what materials were used in the land reclamation of Palm Jumeirah island and from where they were sourced.</p> <p><b>Discuss</b> with you child the different types of soil and the different layers of soil.</p> <p><b>Encourage</b> your child to research and find out how rocks were formed on Earth. Find out the names of different types of rocks such as igneous, sedimentary and metamorphic; how they were formed as well as their properties/characteristics.</p>	<p><a href="#">Rocks and Soils</a></p> <p><a href="#">Types of Soil</a></p>  <p><a href="#">Layers of the Earth</a></p>  <p><a href="#">Types of Rocks</a></p>
-----------------------	--	--	---

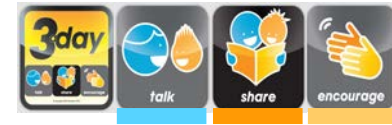

# The Winchester School

## Year 3 Family Learning Newsletter **February 2022**



		<p>Along with your child become a <b>Rock detective</b>. Spot how materials from rocks are used inside the house (tiles, toilets, basins, plaster, bricks, roofing materials, steps) and outside the house (playground, pavements, walls, posts etc).</p> <p>Share with your child the different kinds of architectural structures in Dubai. Tell your child about the oldest houses built and what stones they were made of.</p> <p>Guide your child to illustrate and write what they observe.</p>	
<p><b>Moral Education</b></p>	<ul style="list-style-type: none"> <li>• To recognize that we are all different and why this is to be welcomed and respected.</li> <li>• To praise and celebrate special features in others.</li> </ul> <p>To know who and what should be respected.</p>	<p><b><u>Talk and Encourage the children to do the following:</u></b></p> <ul style="list-style-type: none"> <li>• <b>Talk to your child about the importance of respect and how to praise and celebrate others achievements.</b></li> <li>• <b>Encourage your child to follow the same in real life situations.</b></li> <li>• <b>Speak to your child and engage him/her through different stories of respect and the importance of valuing others in real life.</b></li> </ul>	<p><a href="#">Moral education values</a></p> <p><a href="#">Respect (liveworksheets.com)</a></p> <p><a href="#">wellbeing-identity</a></p>





# The Winchester School

## Year 3 Family Learning Newsletter **February 2022**

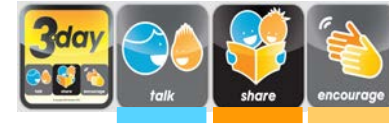



<p><b>Humanities</b></p> <p><b>History</b></p> <p><b>Geography</b></p>	<p>Mummification</p> <ul style="list-style-type: none"> <li>To explore the ancient Egyptian ritual of mummification.</li> </ul> <p>Sketch Maps &amp; Using a Key.</p> <ul style="list-style-type: none"> <li>To create a simple sketch map to show how land is used.</li> <li>To observe, measure, record and present the human features in the local area in the context of creating sketch maps.</li> </ul>	<p><b>Encourage</b> your child to research ancient Egypt.</p> <p><b>Share</b> with your child information about Ancient Egypt: homes, jobs, how to survive, death and travel.</p> <p><b>Talk</b> about the rituals of mummification after researching it.</p> <p><b>Encourage</b> your child to name landmarks seen in a chosen area.</p> <p><b>Share</b> with your child information about pictures or images of the area you visited as it used to look and what things have changed?</p> <p><b>Talk</b> about how would you describe the area you have visited to a group of tourists?</p>	<p><a href="#">Mummification</a></p> <p><a href="#">Ancient Egypt and mummification</a></p> <p><a href="#">Mummification - process</a></p> <p><a href="#">Land Use</a></p> <p><a href="#">Learn about maps</a></p>
<p><b>UAE Social Studies</b></p>	<p>Abu Dhabi and Dubai</p> <ul style="list-style-type: none"> <li>To know and learn about Abu Dhabi as one of the Emirates and the capital city of UAE.</li> <li>To explore facts about Dubai as one of the Emirates.</li> </ul>	<p><b>Encourage</b> your child to research 3-4 facts about the emirates on the internet and make a short photo album.</p> <p><b>Share</b> by showing the world map and locating UAE on the map.</p> <p><b>Talk</b> about the seven Emirates and share with your child some of the landmarks in Abu Dhabi.</p>	<p><a href="#">7 Emirates song</a></p> <p><a href="#">Abu Dhabi</a></p>

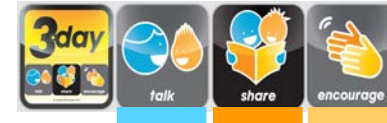

# The Winchester School

## Year 3 Family Learning Newsletter February 2022

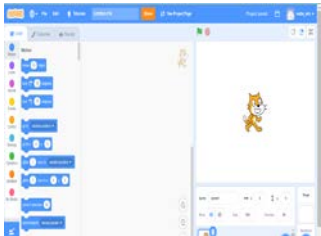

<p><b>SCRATCH Programming</b></p>      <p><b>Creating stories, games and animations</b></p>	<p>To explore the features of SCRATCH i.e. inserting the sprite, creating a stage and moving the sprite.</p>   <ol style="list-style-type: none"><li>1. To make a sprite (or more sprites) move forever or control the movement of the sprite in a direction.</li><li>2. To switch the costume of the sprite.</li><li>3. To switch the backdrops</li><li>4. Create a scene of fantasy story by using the, ‘Say instruction’, ‘Wait instruction’ and ‘Repeat instructions’.</li><li>5.Importing sprites and background from google.</li></ol>	<p>Creativity, Collaboration, Reasoning.</p>   <p>Support your child with activities based on different scenarios Example:  Create a Covid story, Quiz on Cyber Safety, Birthday Card with animation or a game.</p>  <p>Visit the link and explore more ideas and tutorials.</p>  <p>Encourage your child to create a scenario-based project.</p>	<p><a href="https://scratch.mit.edu/explore/projects/all">https://scratch.mit.edu/explore/projects/all</a></p>    <p><a href="https://scratch.mit.edu/">https://scratch.mit.edu/</a></p>
---	---	--	---



# The Winchester School

## Year 3 Family Learning Newsletter **February 2022**

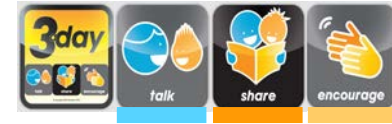

<p><b>Music Year03</b> <b>(Kiko)</b></p>	<ul style="list-style-type: none"> <li>Improving children’s confidence and musicality through singing actions songs and chanting rhymes.</li> <li>Improving on listening skills and recalling.</li> </ul>	<ul style="list-style-type: none"> <li>Let the children sing action songs at home.</li> <li>Ask the child to perform the songs we learned in school.</li> <li>Help the child choose which other songs they know aside from the songs taught in school and let them invent their own singing actions.</li> </ul>	<p><a href="#">Songs for kids</a></p>
<p><b>Music Year03</b> <b>(Sunil)</b></p>	<p>Learning how to play the song “Mary had a little lamb” on recorder</p>	<ul style="list-style-type: none"> <li>Let the child practice at home, even though there will be squeaking.</li> <li>Be an audience. But better also check if the child is holding the recorder properly.</li> </ul>	
<p><b>Music Year03</b> <b>(Joyson)</b></p>	<ul style="list-style-type: none"> <li>Improving child’s confidence and musicality through music rhythm reading for beginners.</li> </ul> <p>We explore the relationship between quarter and eighth notes in 4/4 time</p>	<ul style="list-style-type: none"> <li>Let the child understand the music note value and clap with the notes.</li> <li>Ask the child to perform it with any percussion instrument like maracas, tambourine or recorder by</li> </ul>	<p><a href="#">(22) Introduction to Rhythm Reading: Stage One - YouTube</a></p>



# The Winchester School

## Year 3 Family Learning Newsletter February 2022

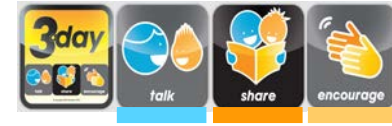

<p>Arabic for Arabs</p>	<p><b>*فكر في حياتك :</b></p> <ul style="list-style-type: none"><li>- أن يفسر التلميذ المفردات الجديدة في النص المعلوماتي .</li><li>- أن يقرأ التلميذ النص قراءة سليمة خالية من الأخطاء .</li><li>- أن يوضح التلميذ الأعمال الابتكارية التي يمكن أن يقوم بها .</li><li>- أن يطرح التلميذ أسئلة عن الفكرة الرئيسية والفكر الفرعية في النص مبدئياً رأيه في المضمون.</li></ul> <p><b>* أسلوب العطف :</b></p> <ul style="list-style-type: none"><li>- أن يميز التلميذ أسلوب العطف .</li><li>- أن يحدد التلميذ حروف العطف ودلالاتها .</li><li>- أن يفرق التلميذ بين المعطوف – المعطوف عليه .</li></ul> <p><b>* هيا نعمل :</b></p> <ul style="list-style-type: none"><li>- أن يفسر التلميذ المفردات الجديدة في النص .</li><li>- أن يطرح التلميذ أسئلة عن الفكرة الرئيسية والفكر الفرعية في نصوص شعرية ، مبدئياً رأيه في المضمون .</li><li>- أن يحدد التلميذ بعض الجماليات في النص .</li><li>- أن يميز التلميذ بعض الأساليب الإنشائية والخبرية .</li><li>- أن يعدد التلميذ فوائد العمل.</li></ul>	<p><b>يستطيع السيد ولي الأمر أن يساعد الطالب عن طريق:</b></p> <p>مساعدة الطالب على استخدام الكلمات الجديدة في تعبيراته داخل المنزل.</p> <p>مساعدة الطالب على القراءة السليمة للنصوص المدروسة .</p> <p>مساعدة الطالب في الربط بين خبراته ومعلوماته السابقة وبين ما يتعرفه من معلومات جديدة.</p> <p>مساعدة الطالب في الحديث مستخدماً أسلوب العطف.</p> <p>مساعدة الطالب في البحث عن أبيات شعرية تحوي أسلوب العطف .</p> <p>حث الطالب على الاجتهاد في عمله .</p> <ul style="list-style-type: none"><li>- يمكن لولي الأمر الدخول من خلال الرابط المرفق لموقع قناة اللغة العربية والتربية الإسلامية الخاص بمدرسة ونشستر ومتابعة التسجيلات الخاصة بالدروس ومشاركتها مع التلميذ وتدوين ما تعلمه في دفتره المدرسي.</li></ul>	<p><a href="#">منصة أقرأ بالعربية</a></p> <p><a href="#">الفكر والإبداع والابتكار</a></p> <p><a href="#">حروف العطف</a></p> <p><a href="#">قناة اللغة العربية والتربية الإسلامية</a></p> <p><a href="#">بمدرسة ونشستر</a></p>
<p>Arabic for Non-Arabs</p>	<p><b>Places Around Me</b></p> <ul style="list-style-type: none"><li>- To distinguish between different places.</li><li>- To create sentences about the places.</li><li>- To describe Dubai using new vocabulary and adjectives.</li><li>- To express opinion in different places.</li><li>- To compare between two places.</li></ul> <p><b>Clothes shop</b></p> <ul style="list-style-type: none"><li>- To make sentences about the clothes shop.</li></ul>	<p>In every new lesson, we provide new words with its meanings.</p> <p>Help your child to memorize them and use them in sentences on his/her own.</p> <ul style="list-style-type: none"><li>- Help your child to link between the picture and the word.</li><li>- Ask your child to draw places and clothes and describe them.</li></ul>	<p><a href="#">Places</a></p> <p><a href="#">ARABIC COLOURS</a></p> <p><a href="#">Clothes in Arabic</a></p> <p><a href="#">I Read Arabic</a></p> <p><a href="#">Arabic and Islamic YouTube Channel</a></p>



# The Winchester School

## Year 3 Family Learning Newsletter February 2022

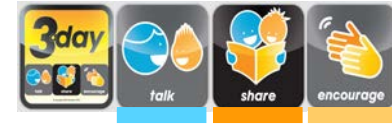



	<p>- To know the difference between colors with masculine and feminine. To express opinion on clothes. - To compare between the four seasons.</p>	<p>- Go through the links on the Arabic YouTube channel so that you can help your child learn more at home about the topic.</p>	
<p>Islamic for Arabs</p>	<p><b>التسامح</b> أن يستنتج التلميذ مفهوم التسامح في الإسلام أن يحلل التلميذ مجالات التسامح أن يدلل التلميذ من القرآن والسنة على فضل التسامح في الإسلام</p> <p><b>أبو بكر الصديق</b> أن يستنتج التلميذ صفات سيدنا أبو بكر الصديق أن يشرح التلميذ دور سيدنا أبو بكر في الدعوة أن يدلل التلميذ على أهمية صحابة الرسول في الإسلام</p> <p><b>سورة الفجر</b> أن يبين التلميذ المعنى الإجمالي للآيات الكريمة أن يستنتج التلميذ عاقبة الظالمين . أن يفسر التلميذ بعض معاني الآيات الكريمة .</p>	<p>حث التلميذ على التزام آداب التلاوة الصحيحة. حث التلميذ على الأعمال الصالحة . حث التلميذ على التسامح مع الآخرين . مساعدة التلميذ في الاستماع لسورة الفجر من خلال المصحف المعلم .</p> <p>- يمكن لولي الأمر الدخول من خلال الرابط المرفق لموقع قناة اللغة العربية والتربية الإسلامية الخاص بمدرسة ونشستر ومتابعة التسجيلات الخاصة بالدروس ومشاركتها مع التلميذ وتدوين ما تعلمه في دفتره المدرسي.</p>	<p><a href="#">التسامح</a> <a href="#">أبو بكر الصديق</a> <a href="#">سورة الفجر</a> <a href="#">قناة اللغة العربية والتربية الإسلامية</a> <a href="#">بمدرسة ونشستر</a></p>

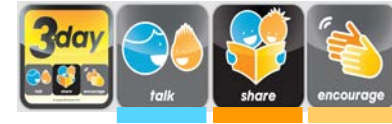

# The Winchester School

## Year 3 Family Learning Newsletter February 2022



<p><b>Islamic for Non-Arabs</b></p>	<p>Unit 3 : (the qualities of the true Muslim)  Unit 3: (Fasting )  Unit 3: (The etiquette of visiting and hospitality)  Learning Objectives:  -To explain why is respecting important in our lives.  - To explain that telling the truth is part of Islam.  - To explore the benefits of telling truth in the life.  - To extract the benefits of fasting.  - To clarify the advantage of being generous in the life.</p>	<p>Talk to your child about truthfulness tolerance and why it is important.  Ask your child to write about a day of fasting in Ramadan.  Encourage your child to learn Surah- ul-Alaq and surat Al- layl within YouTube.  Encourage your child to use the Duaa taught in his life  Encourage your child to be a good example of the good manners in the life.  Go through the links on the Arabic and Islamic YouTube channel so that you can help your child learn more at home about the topic</p>	<p><a href="#">Surat Al Alaq</a>  <a href="#">Fasting</a>  <a href="#">Arabic and Islamic YouTube Channel</a></p>
<p><b>Physical Education</b></p>	<p><b><u>Throw ball/Service:</u></b>  <b>Students will be able to understand the game &amp; how to perform service skills.</b></p> 	<p><b><u>Talk and Encourage the children to do the following:</u></b></p> 	<p><b><u>Useful sites:</u></b>  <a href="https://www.youtube.com/watch?v=VD5HZjM2l0">https://www.youtube.com/watch?v=VD5HZjM2l0</a>  <a href="https://www.youtube.com/watch?v=nUw_8zq06HM">https://www.youtube.com/watch?v=nUw_8zq06HM</a>  <a href="https://www.youtube.com/watch?v=MTi18LoWjOs">https://www.youtube.com/watch?v=MTi18LoWjOs</a></p>



# The Winchester School

## Year 3 Family Learning Newsletter February 2022

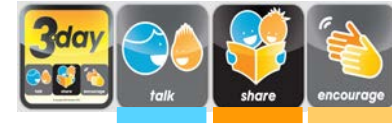

### Throwball/Throwing:

Students will be able to understand how to perform throwing skills.



Encourage your child to take part in Throwball Games, practice more with wall return services to become a master in Servicing skill in Throwball Game.

Talk and Encourage the child to do the following:



Encouraging Children to take part in Throwball Games, practicing more time with wall return throwing or with partner practices to become master in Throwing skill in Throwball Game.

### Useful sites:

<https://www.youtube.com/watch?v=aZTHjSReRYQ>

<https://www.youtube.com/watch?v=S5YNfqxn8v4>



# The Winchester School

## Year 3 Family Learning Newsletter February 2022

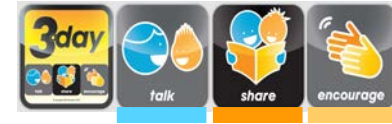

### Throwball/Catching:

Students will be able to understand how to perform catching skills.



### Throwball/Team play:

Students will learn how to play a game with basic rules & will be able to understand of the game.



### Talk and Encourage the child to do the following:



Encourage your child to take part in Throwball Games, practice with wall return throwing/catching, individual or with partner practices to become a master in catching skills in Throwball Game.

### Talk and Encourage the children to do the following:

Encourage your child to take part in Throwball Games, watch the game on YouTube to understand the competency level between the two teams in a throwball match

### Useful sites:

- <https://www.youtube.com/watch?v=EyyL1qU-HRc>
- <https://www.youtube.com/watch?v=1alnZWz8A-Y>
- <https://www.youtube.com/watch?v=FYS9o-Mwl>



### Useful sites:

- <https://www.youtube.com/watch?v=awd3EQtn1lk>
- <https://www.youtube.com/watch?v=WLEKkpRSbAo>
- <https://www.youtube.com/watch?v=gDfJQwVs6aE>